

NO TAPER

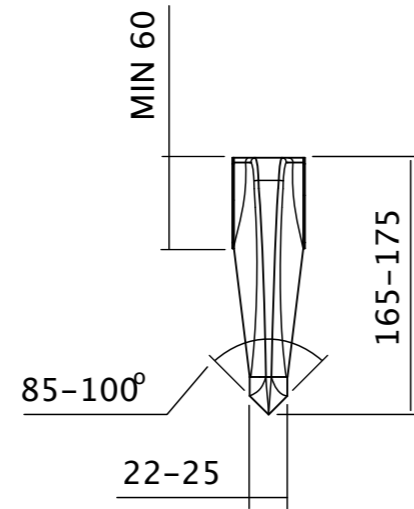

MAX TAPER

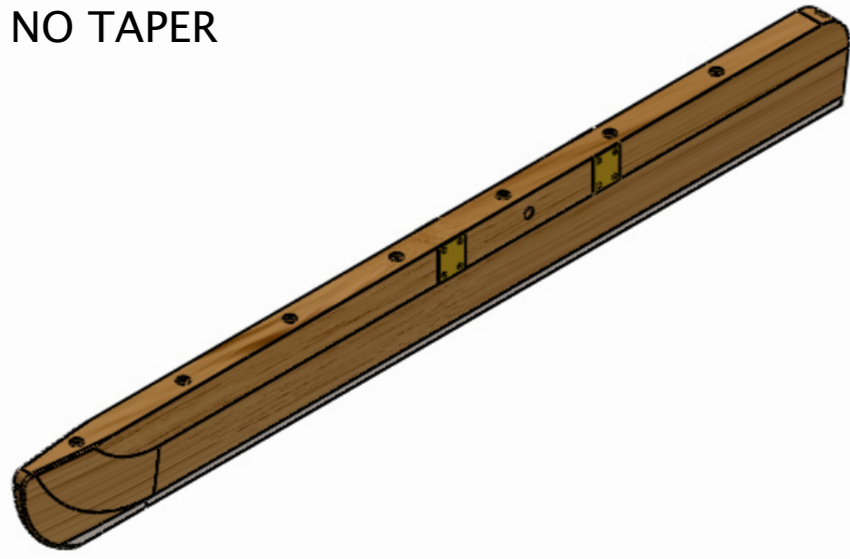

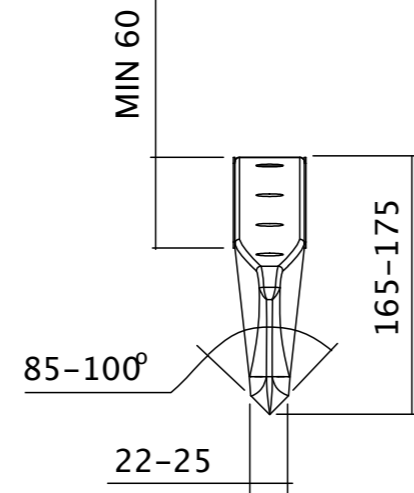
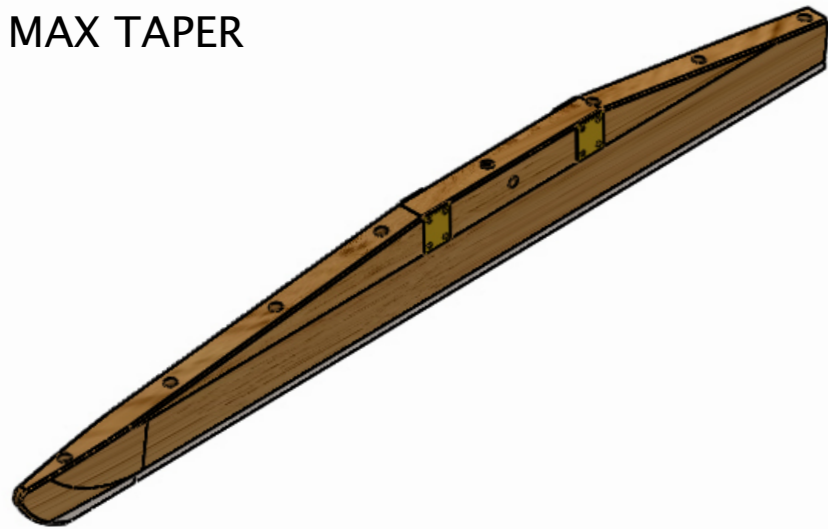

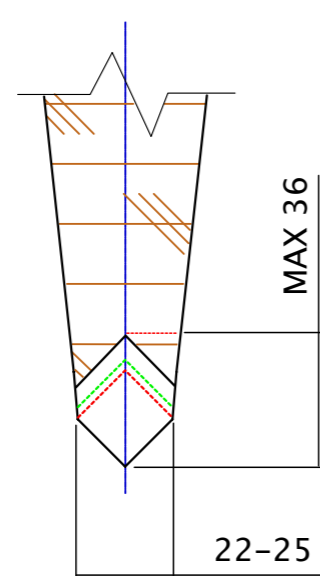
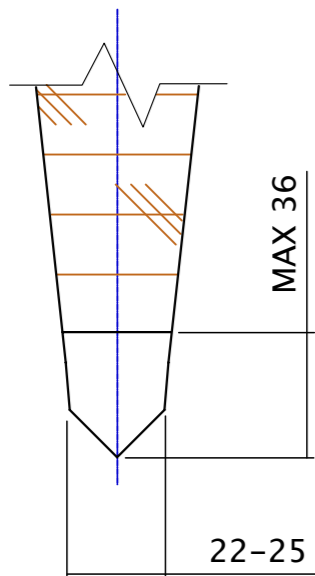
ALLOWED STEEL SHAPES
SCALE 1:2

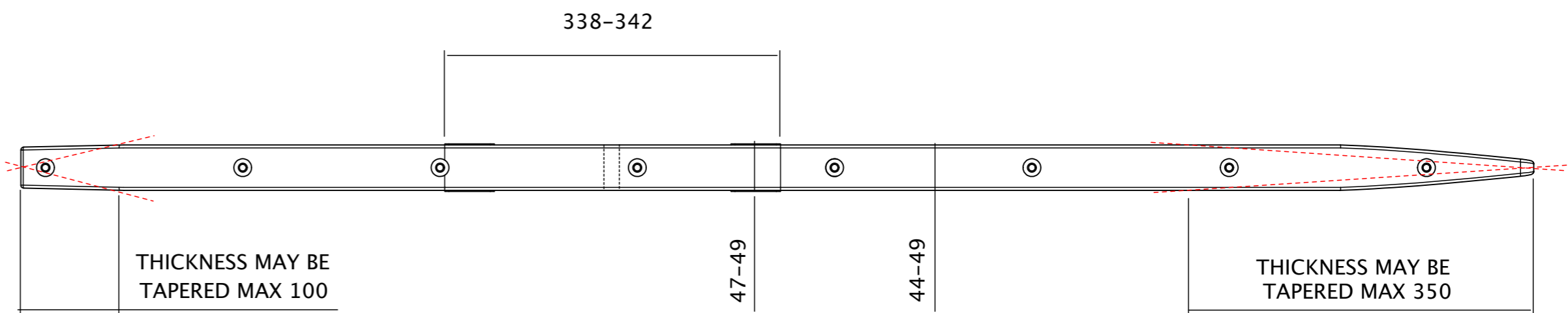
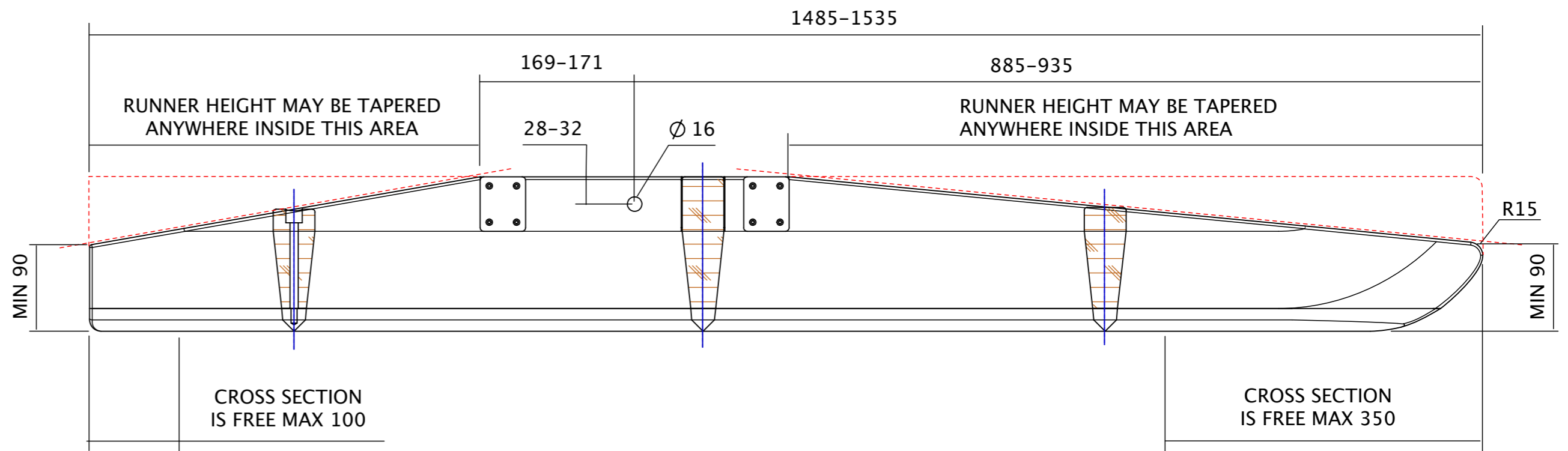
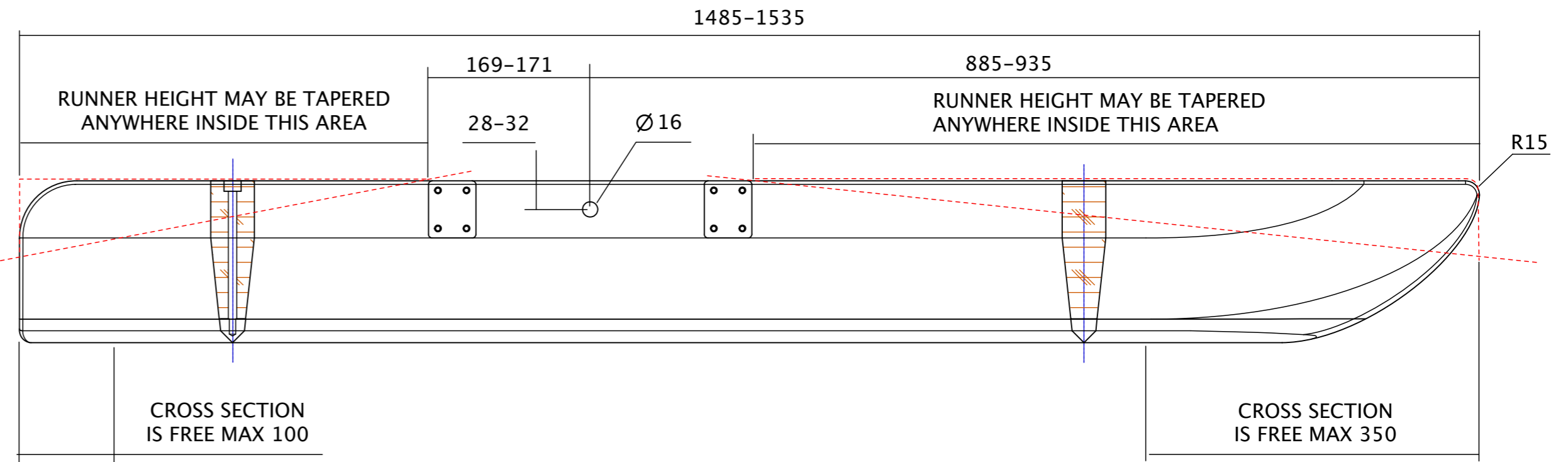

MACHINED
STEEL

- 20X20 SQUARE BAR
- 18X18 SQUARE BAR
- MAX 25X25 SQUARE BAR



				ALL DIMENSIONS IN MM		DO NOT SCALE DRAWING	REVISION: 04	
						OWNER: IMXVIYRA		
DRAWN	J. KINBERG	<i>J. Kinberg</i>	2017-12-17	NOTES: THE HEIGHT OF THE RUNNER CAN BE TAPERED ANYWHERE INSIDE THE RED DOTTED LINES, IN THE SIDE VIEW DRAWINGS. THE THICKNESS CAN BE TAPERED 350 MM IN THE FRONT AND 100 MM IN THE AFT. SEE TOP VIEW DRAWING MATERIAL: HARDWOOD MIN 650 KG/M. FIBERGLASS MAY BE ADDED STEEL	TITLE: MONOTYPE-XV WOOD RUNNER		DWG: WOOD FRONT RUNNER	A2
CHK'D	D. SCHÜTTE		2018-03-25					
CHK'D	A. PADU		2018-03-25					
APPV'D	M. AKERBLAD		2018-06-04		SCALE: 1:5, 1:2		SHEET: 1 OF 2	
MFG	Q.A							